



Active SpaceWire Backplane Development Status

**SpaceWire Working Group 13
September 2009**

**Author: Alan Senior
Email: alan.senior@sea.co.uk**

MARC Demonstrator

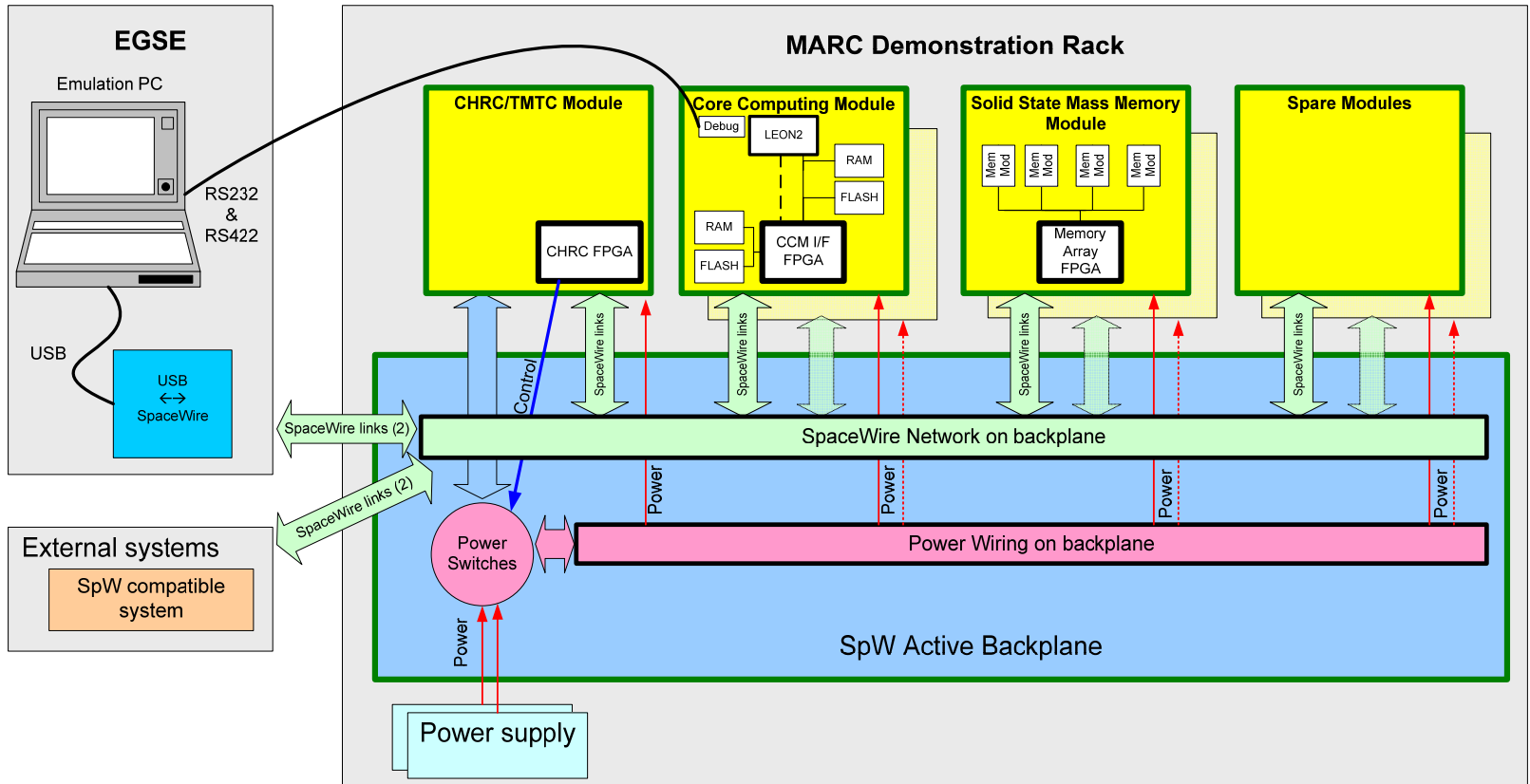

SpW network architecture

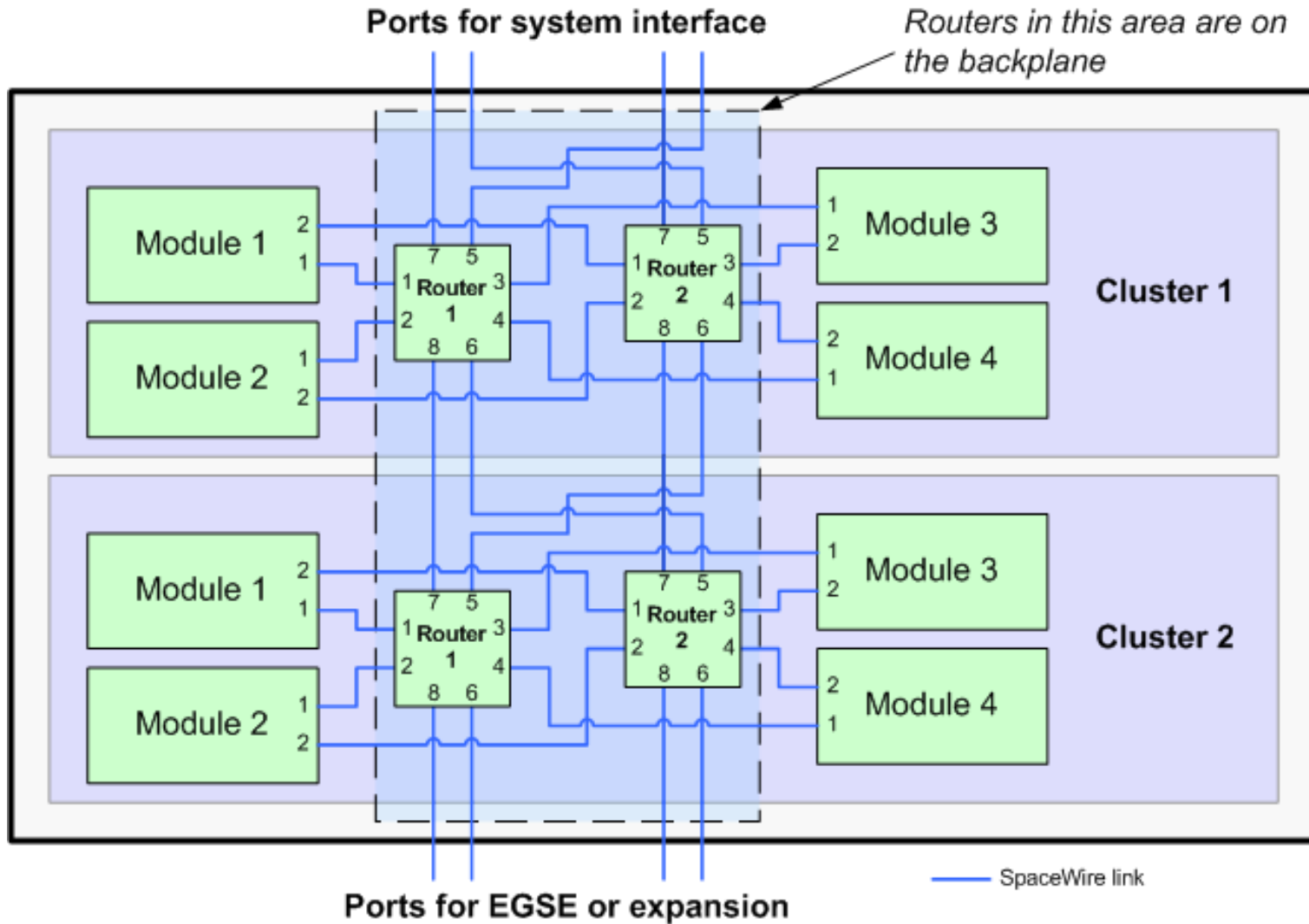

Demonstrator power distribution

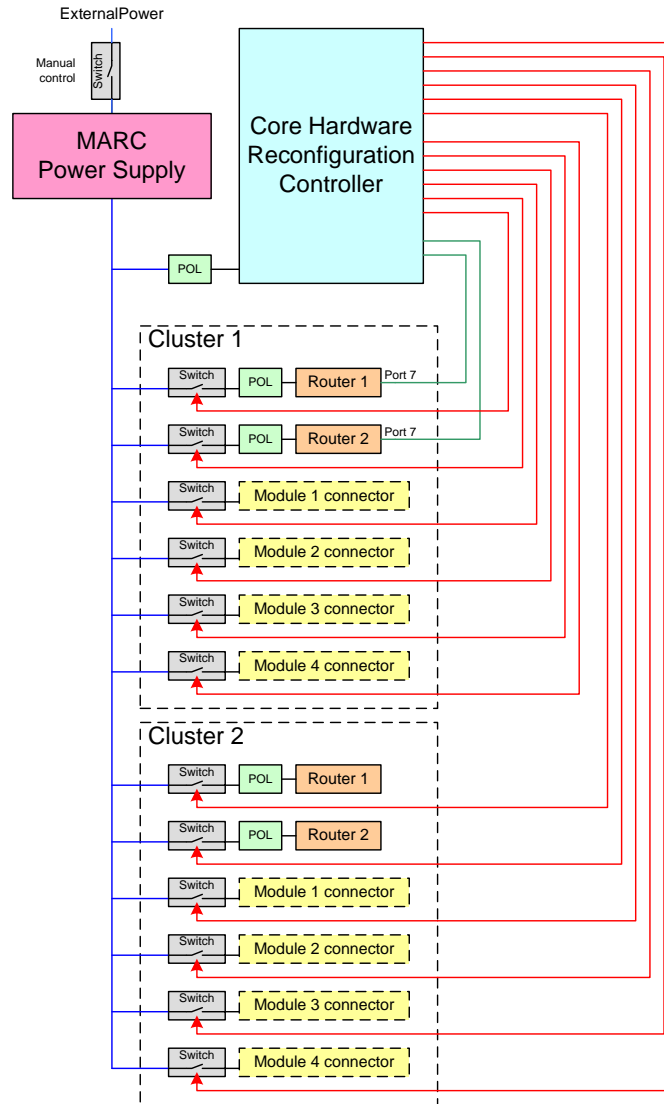

Backplane LCL

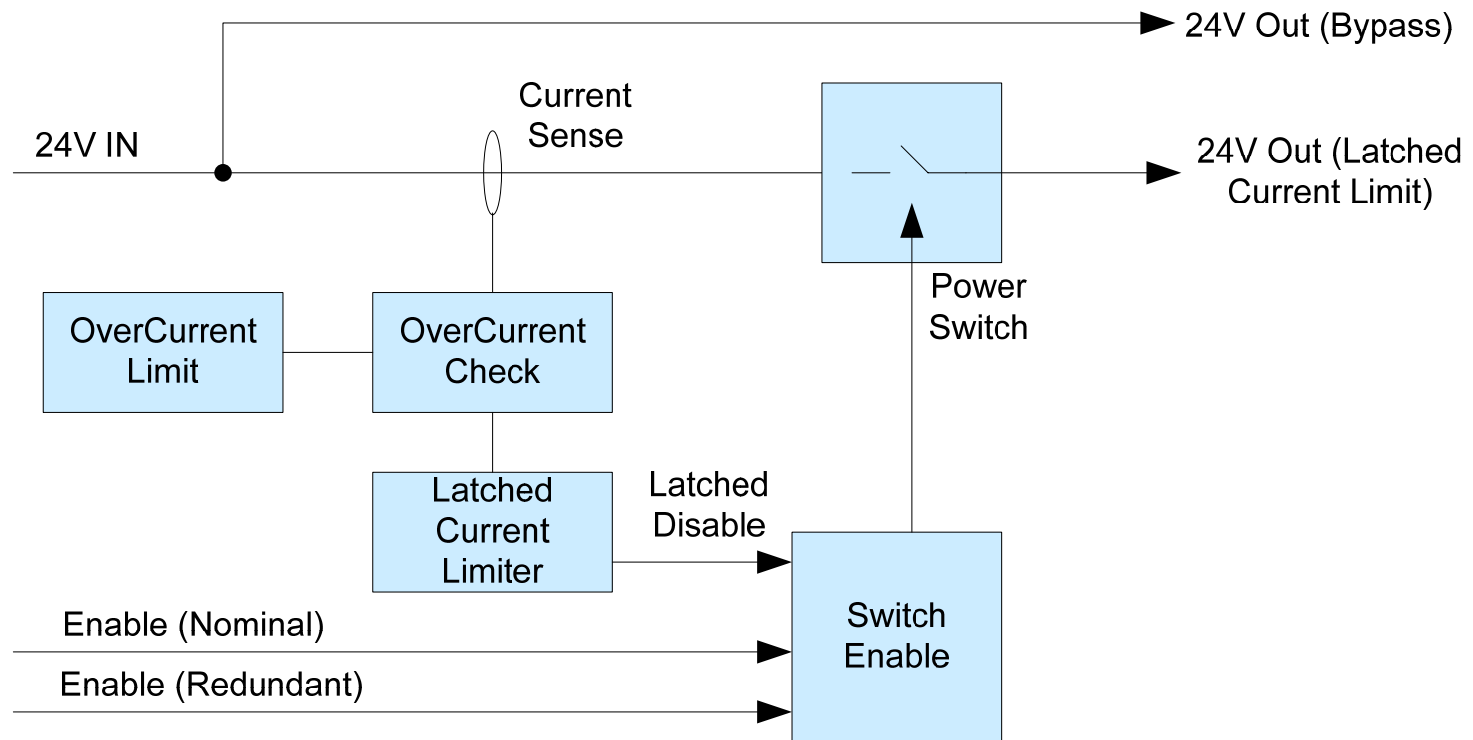

MARC Demonstrator Rack

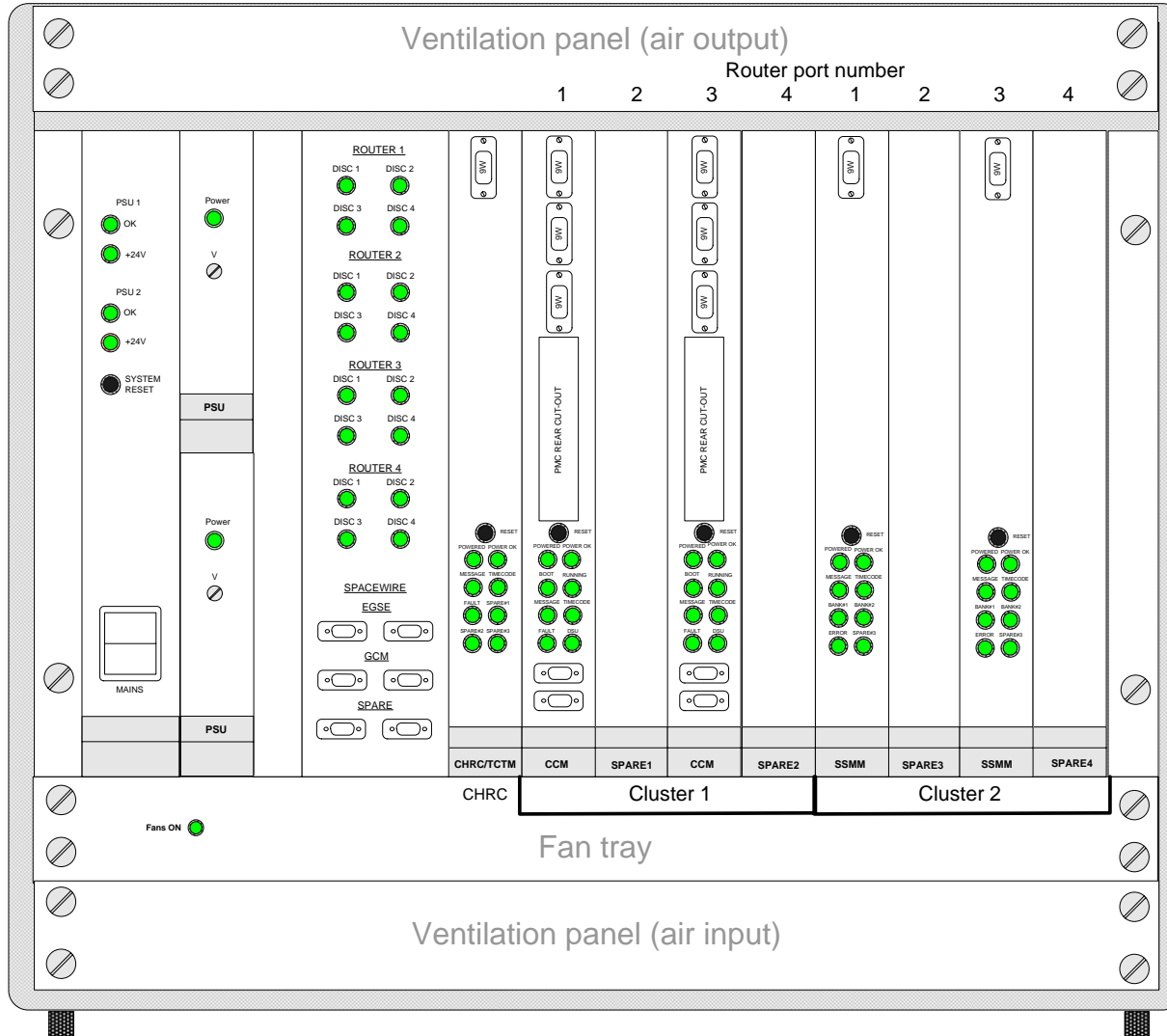

Backplane PCB - front

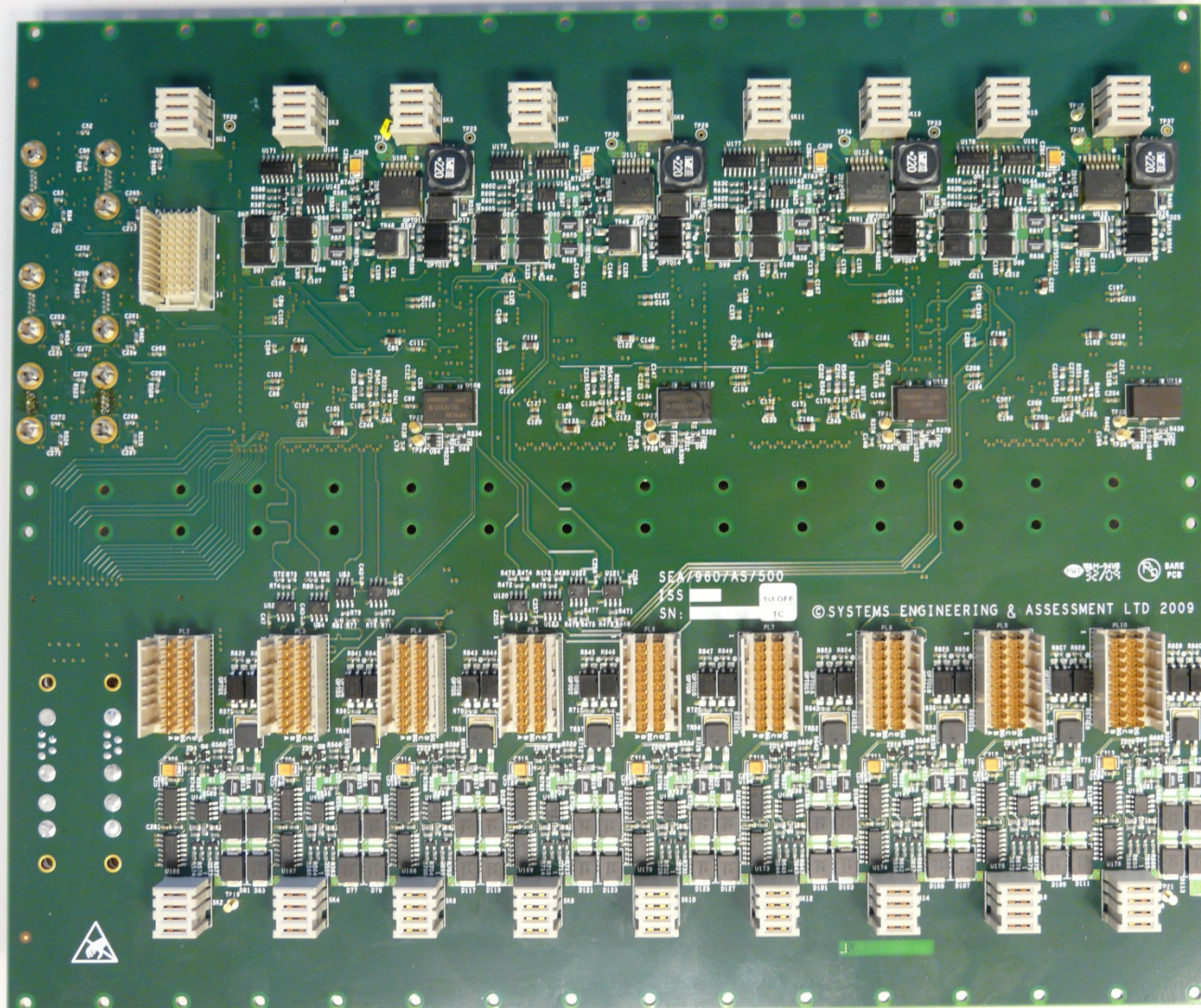

Router DC-DC

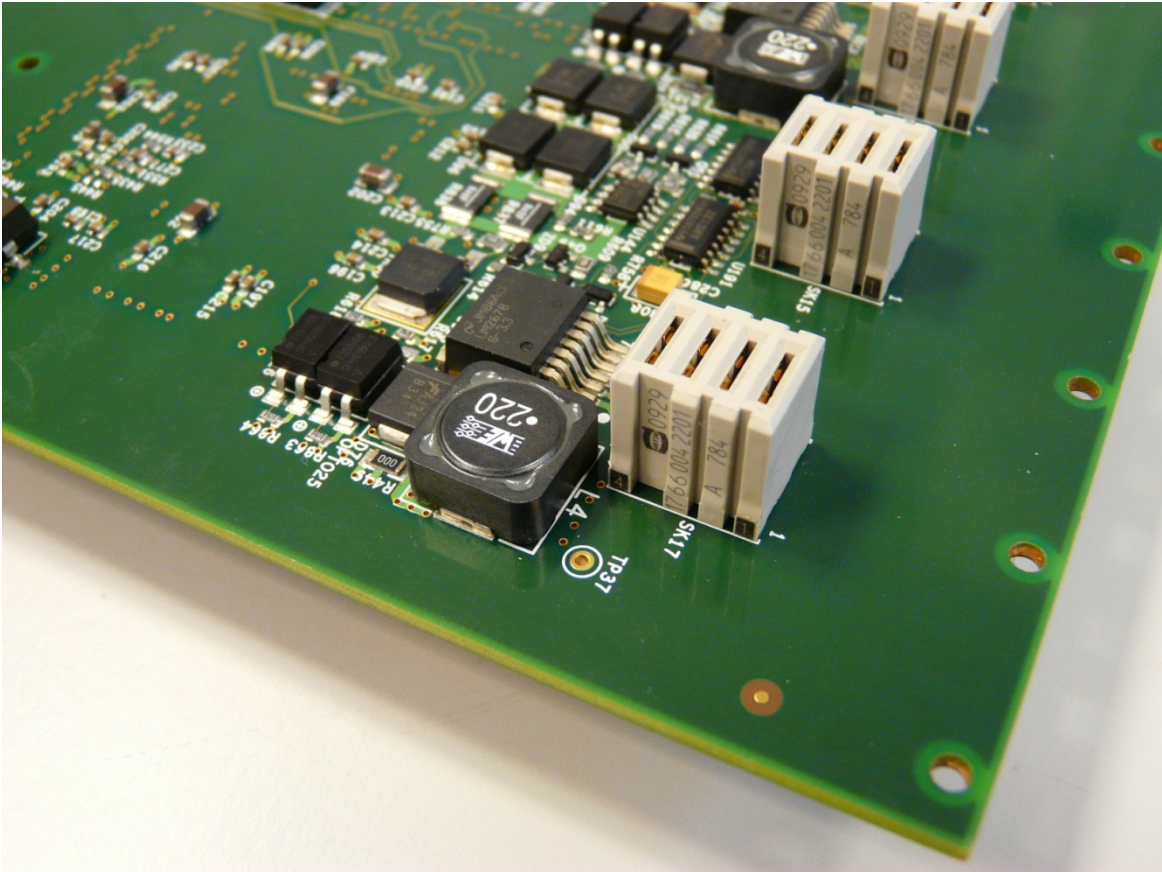

Module LCL

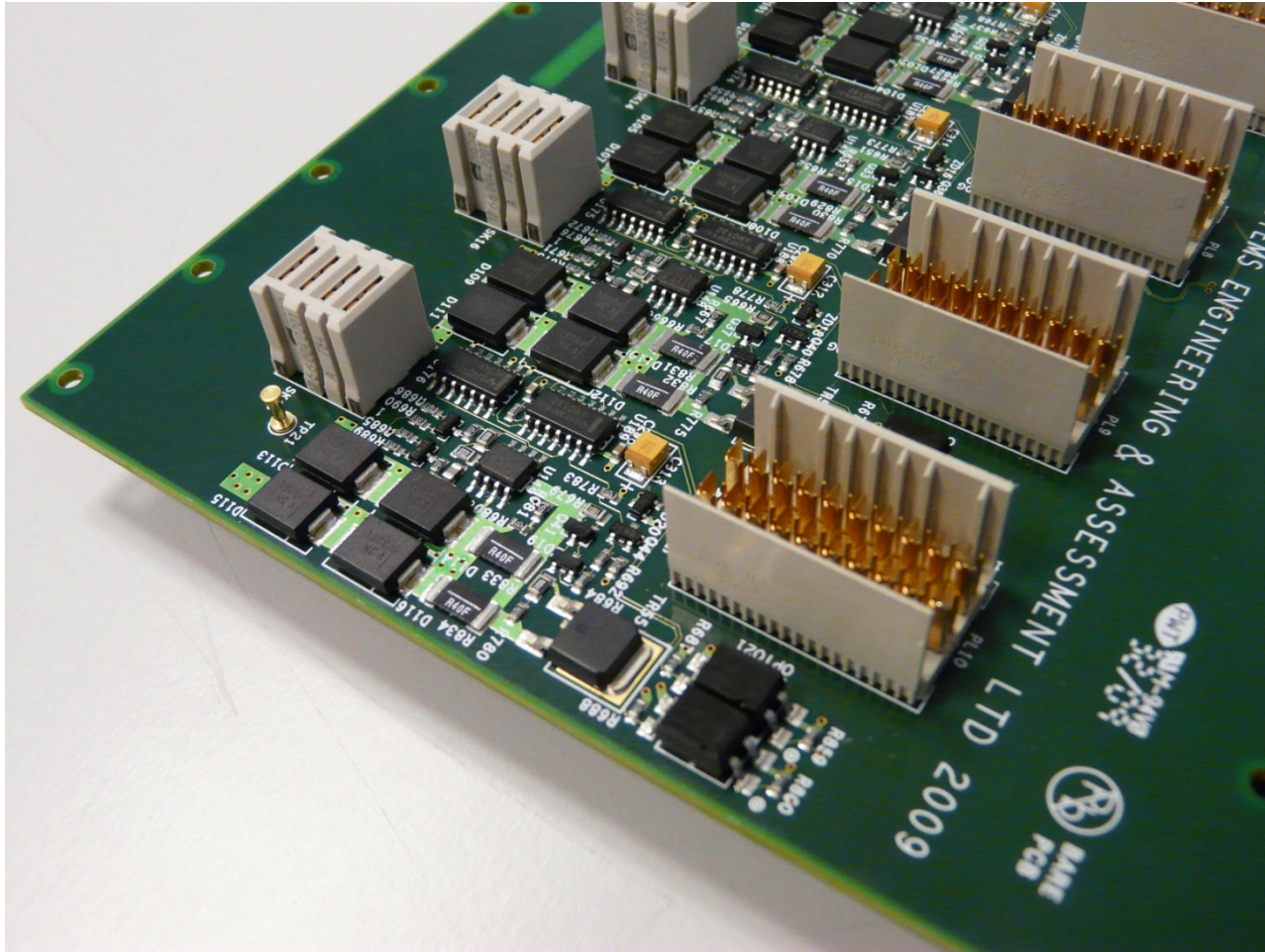

Backplane PCB - back

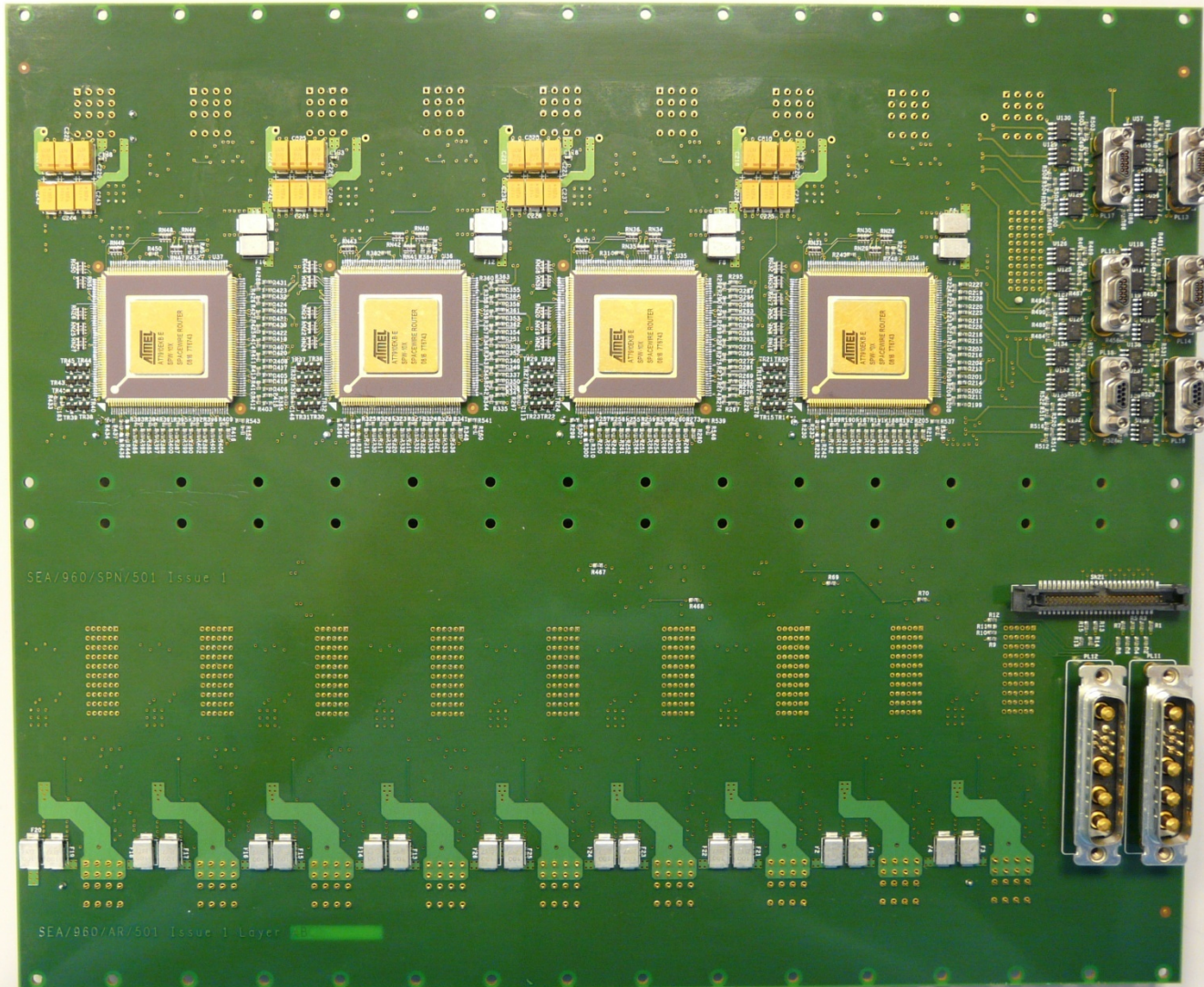

Router detail

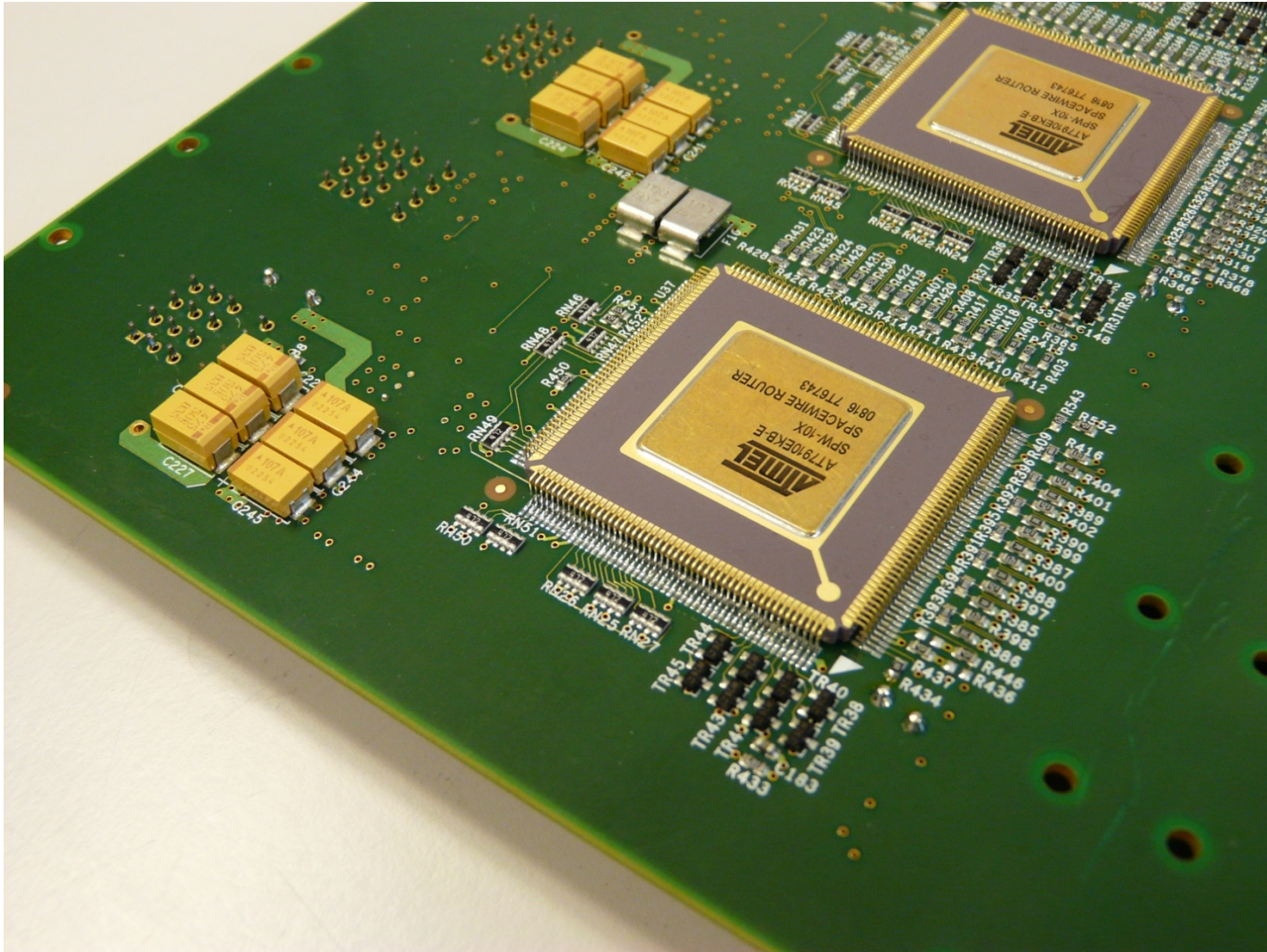

Core Computing Module (CCM)

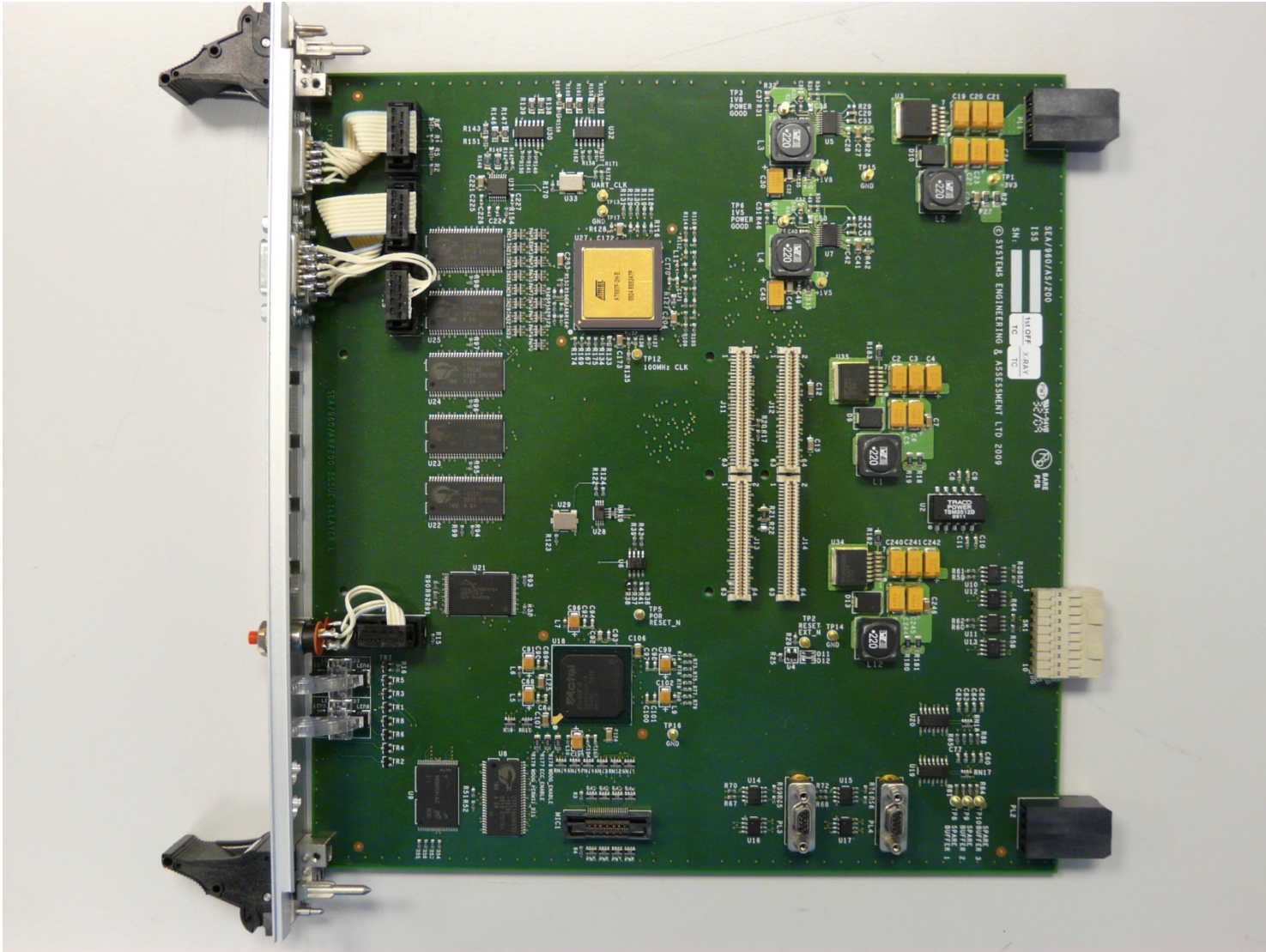

Mass Memory module (SSMM)

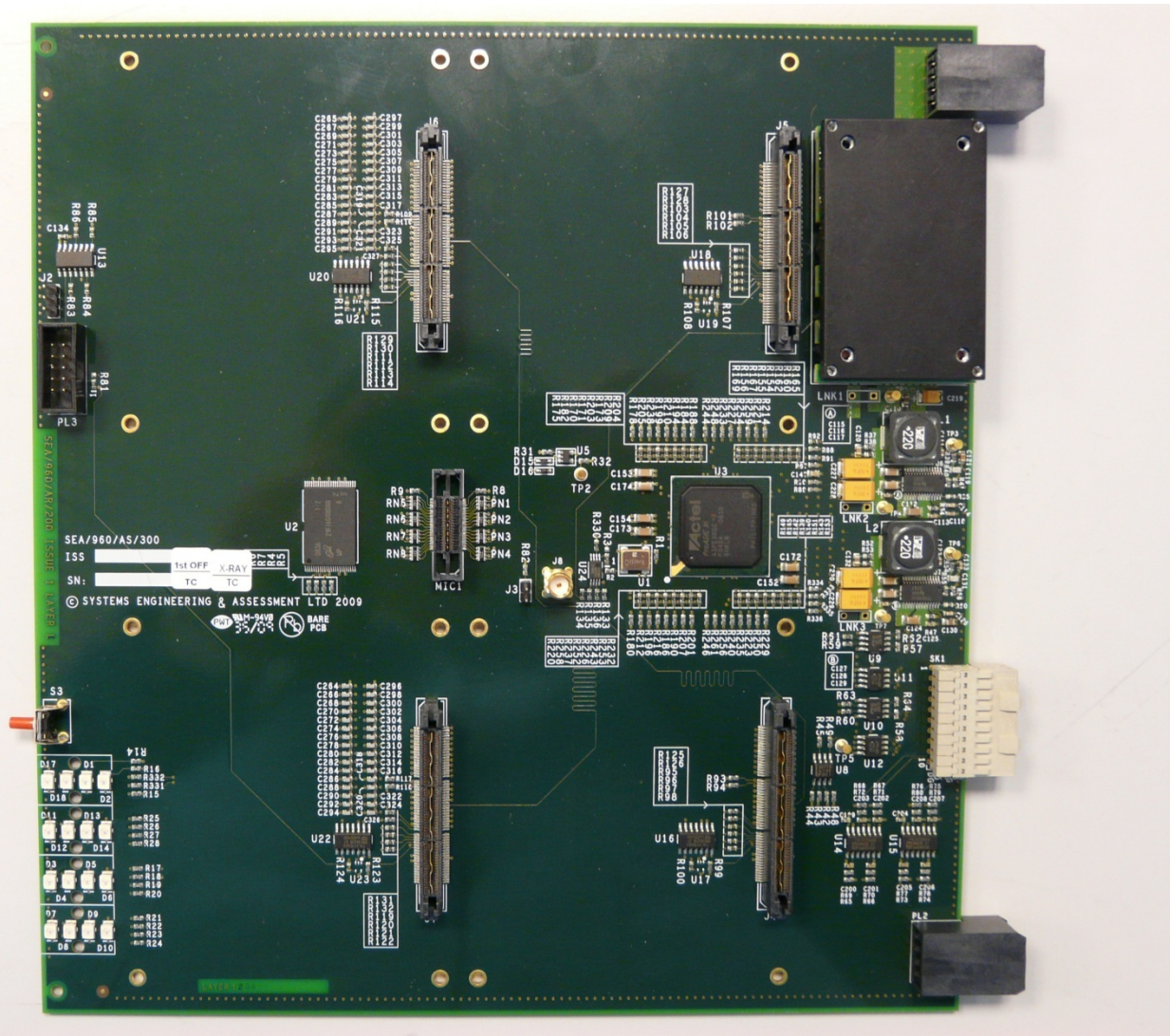

Reconfiguration module (CHRC)

